



**ACCESS LASER**

where innovation never stops

## *L20 Series Operator Manual*



Access Laser Company  
917 134<sup>th</sup> St SW, Suite A1  
Everett, WA 98204  
425.582.8674  
[www.accesslaser.com](http://www.accesslaser.com)

# TABLE OF CONTENTS

<b>SECTION</b>	<b>PAGE</b>
Company Statement.....	2
Contact Information.....	3
Warranty.....	4
The L20 Series.....	5
Laser Shipment Contents.....	6
Safety Information.....	7
Safety Symbols and Terms.....	7
FDA and Federal Regulations.....	8
Safety Label Locations.....	10
Laser Operation Instructions.....	11
Operating the Laser.....	11
Water Cooling Diagram.....	14
Water Cooling Connection Instructions.....	15
Wiring Diagram.....	16
Laser System Connection Diagrams.....	17
Laser Specifications.....	19
L20G Mounting Dimensions (Water Cooled).....	19
L20S, L20SP and L20SD Specifications.....	20
L20G, L20GP, and L20GD Specifications.....	21
RF Driver Specifications.....	22
Appendix A: RF Driver D-sub 15 Connector.....	23
Appendix B: Optional Accessories.....	288
Differential Micrometer (L20G Only).....	28
LC3 Laser Controller Diagram.....	29
Laser Operation Instructions for LC3.....	31
Line Tracker (Optional).....	34
Appendix C: Warranty Repairs.....	35



## Company Statement

Thank you for purchasing an Access Laser product. We remain dedicated to your needs long after your initial purchase. In order to help us meet your needs, please contact us if you have any questions, comments or concerns about your laser, at [sales@accesslaser.com](mailto:sales@accesslaser.com) or call us at 425-582-8674. Our staff will make every effort to assure that your laser is operating at its peak performance. We look forward to working with you through the life of your project.



## Contact Information

Access Laser Company is a multi-national company headquartered in Everett, Washington.

Mailing Address	Access Laser Company 917 134 <sup>th</sup> St SW Suite A1 Everett, WA 98204
Phone Number	425.582.8674
Fax Number	425.582.8679
Email	<a href="mailto:sales@accesslaser.com">sales@accesslaser.com</a>

Access Laser Company specializes in innovative solutions to meet your application needs. Our Sales Team and Customer Service Team can provide you with the most up-to-date product information. If you need assistance with an order or service, contact Access Laser Company at 425.582.8674, ext.1 or email your questions.

Sales/Technical Questions	<a href="mailto:sales@accesslaser.com">sales@accesslaser.com</a>
---------------------------	--

Service Department	<a href="mailto:service@accesslaser.com">service@accesslaser.com</a>
--------------------	--



## Warranty

All of Access Laser Company's lasers come with a one-year standard warranty, which certifies that your laser is found to be free of any defects in material or workmanship. This warranty applies regardless of your laser application. It does not cover any issues that may arise due to operator negligence, environmental factors, accident, alterations, or improper maintenance.

Access Laser Company requests that you inspect your shipment within 14 days of arrival. If there appears to be any damage or defect you must notify Access Laser Company, in writing, at [service@accesslaser.com](mailto:service@accesslaser.com). If Access Laser Company is not notified within 14 days, we will assume that the shipment arrived in satisfactory condition.

Please complete the information below upon final inspection of your order.

Date Received:

---

Laser Model:

---

Laser Serial Number:

---

RF Driver Serial Number:

---

Received By:

---

Access Laser Company and its Authorized Distributors maintain the sole authority to make any claims or statements regarding warranty on Access Laser Company products. Access Laser Company reserves the right to make changes or improvements to product design without notice, and without expectation of equivalent changes in products previously manufactured or shipped.



## The L20 Series

The L20S Series lasers have an operating power of 20 Watts in Continuous Wave mode. The L20S is the standard model in the series. The L20SP offers a Super Pulse option, with a peak power of 50 Watts. The L20SD provides the functionality of either the L20S or the L20SP, by simply changing the power supply voltage.

The L20G models are grating tunable lasers with an operating power of 8 Watts in Continuous Wave mode. The L20G models provide a broader wavelength range, with the option of Super Pulse found in the L20GP. The L20GD provides the functionality of either the L20G or the L20GP, by simply changing the power supply voltage. Operations of the L20S, L20SP, L20SD, L20G, L20GP, and L20GD are covered in this Operator Manual.

Accessories are available in the L20 series. Operation instructions for these accessories are included in the Appendices of the Operator Manual, or in a separate manual, included with your shipment.

Because Access Laser Company provides innovative solutions to meet your needs, many specialty features are possible with the L20 series. Many of these specialty features may alter the appearance of your laser from what is pictured in the Operator Manual, but they do not alter the basic specifications or operation instructions for your laser. If you have any questions about the specifications or operation of your laser, please feel free to contact us at 425-582-8674, ext 1.



## Laser Shipment Contents

The following items are typically included in each laser shipment:

- L20 Series Laser
- RF Driver
- BNC to TNC Coax Cable (2)
- D-sub 15 Dongle
- L20 Series Laser Operation Manual
- Laser Test Documents
  - Final Test Document
  - Pulse Power Document
  - Power Plot

If you have questions about the contents of your shipment, please contact us.

# Safety Information

## *Safety Symbols and Terms*

Commonly used safety symbols and terms are used throughout this manual and on our products. Please familiarize yourself with the definitions and use of the terms and symbols.



Indicates a hazardous situation which, if not avoided, will result in death or serious injury.



Indicates a hazardous situation which, if not avoided, could result in death or serious injury.



Indicates a hazardous situation in which, if not avoided, could result in minor or moderate injury.

**CAUTION:** Indicates an unsafe practice that can result in property damage.

**Note:** Additional information provided for optimal product performance.





# Safety Information

## *FDA and Federal Regulations*

Access Laser Company has designed our lasers to comply with CDRH requirements set forth by United States Radiation Control Health Act of 1968. Therefore the L20 series lasers meet all standards for laser products under 21CFR 1040.10 and 21CFR 1040.11. These standards have been set forth to protect the end user from harmful radiation. It is the responsibility of the end user to assure compliance with any and all regulations related to final use or when used outside the United States.



### Never Open the Laser

To prevent direct exposure from the laser beam and injury to the user, do not try to open the laser. Opening the laser may result in burns or eye damage or misalignment of the laser or other damage to the laser. The end user will never need to open the laser for maintenance or any other reason. All laser parts are serviceable only by authorized Access Laser personnel. Disassembling the laser voids any warranty.



### Eye Protection Required

The L20 series lasers are Class IV lasers. Class IV Lasers have power outputs of greater than 500 mW. This laser can cause mild to severe burns if skin or eyes are exposed to the beam or scattered radiation. Protective eyewear should be worn at all times.

**▲ CAUTION** Use of controls or adjustments or performance of procedures other than those specified herein may result in hazardous exposure.

**▲ CAUTION** Use Appropriate Beam Blocks

The L20 series lasers produce laser radiation around 10.6 $\mu$ m. This wavelength is invisible and requires special equipment to detect or view. Some materials may cause the laser beam to reflect and scatter, causing injury or damage. Take precautions to block the beam from unintentional reflection. Avoid using materials such as copper, aluminum, or gold as beam blocks which are highly reflective and may cause the beam to scatter. Organic materials may be flammable when exposed to the laser beam. Never use organic materials such as plastic or wood as a beam block. Use a beam block designed for the wavelength and power of your laser, or use a laser power meter.

## Safety Information

### *FDA and Federal Regulations*

#### **CAUTION**     Water Cooled Lasers

For water cooled lasers, do not leave the chiller running while the laser is powered off. This may cause condensation in the electrical circuits and optical components, which will lead to damage.

#### **CAUTION**     Super-Pulse Lasers

For Super Pulse lasers (-P model), running the laser above a 30% duty cycle or 400 $\mu$ s pulse length may damage the RF driver. The internal protection program will interrupt the user signal beyond these parameters, making the output inconsistent.



# Safety Information

## Safety Label Locations

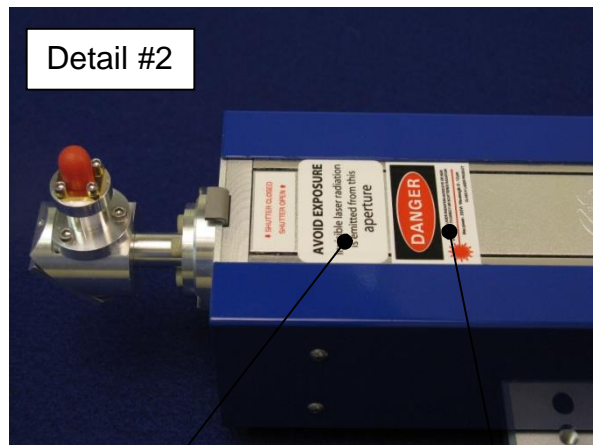
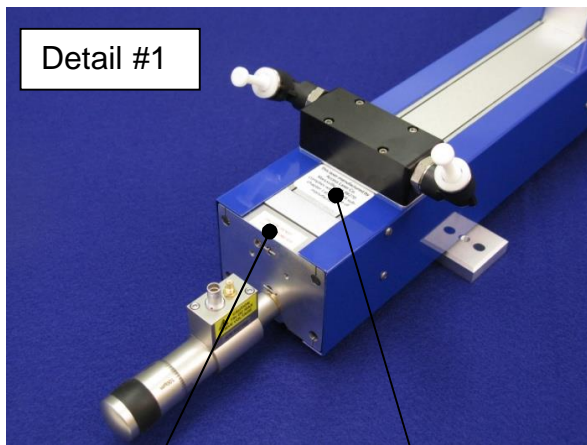
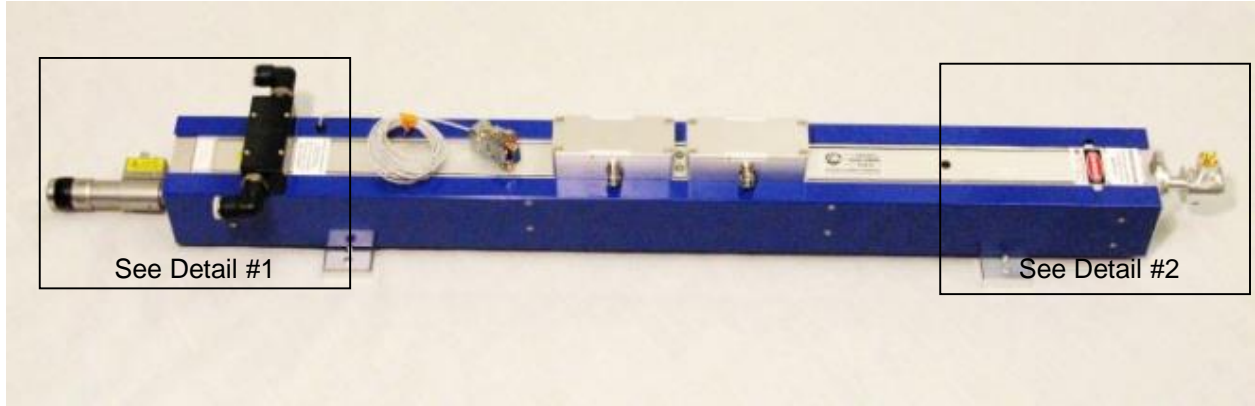

Detail #1

Detail #2

**CAUTION: DO NOT LIFT BY MICROMETER**

Non-OEM\*

This laser manufactured by Access Laser Co. Everett, WA 98204 complies with 21 CFR subchapter J at the date of manufacture.

OEM\*

This laser manufactured by Access Laser Co. Everett, WA 98204 does not comply with 21 CFR sub-chapter J at the date of manufacture.

**AVOID EXPOSURE**  
Invisible laser radiation is emitted from this aperture

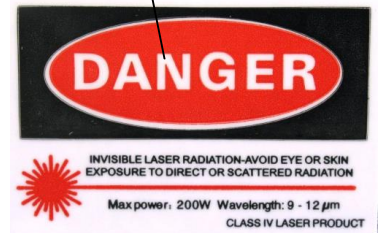

\* All non-OEM lasers comply with 21 CFR subchapter J at the time of manufacture. If your laser is a custom order (OEM), it is your responsibility to assure compliance with CFR in your final application.



# Laser Operation Instructions

## Operating the Laser

**NOTE:** *If using the LC3 controller, follow the instructions under “Appendix B”.*

1. Close the laser shutter (if present).
2. Direct the laser toward an appropriate target, such as a power meter or a beam-blocking device. (See Safety Information regarding appropriate beam blocking devices.)
3. Secure the laser to a bench top.

### **⚠ CAUTION**

Do not torque, twist or bend the laser body during the mounting process. Applying uneven pressure to the laser body may distort the laser body, causing poor performance and possible damage.

4. Connect the Cooling System
  - a. Air Cooled Lasers (where cooling is provided by the end user)
    - i. If no cooling is built in to your laser, you are responsible for providing sufficient cooling to maintain the laser specifications. (See Air Cooling Section for specifications.)
    - ii. Connect your air cooling system to the laser.
  - b. Built-in Fan Cooled Lasers

Connect the 12V DC supply to the fan power connector.
  - c. Built-in Water Cooled Lasers
    - i. Connect the tubing to the PISCO fitting as described in the Water Cooling Connection Instructions.
    - ii. Connect the tubing to the laser and the chiller, as shown in the Water Cooling Connection Diagrams. Be sure that the tubing input and output are the same on both sides of the laser.
5. Connect the RF Driver to the laser with the two coax cables, using the TNC and BNC connectors, as shown in the Wiring Diagram and Connection Diagrams.
6. Connect your 5V TTL source to the RF Driver via the TTL gate (BNC connector).



# Laser Operation Instructions

## Operating the Laser

7. Set the TTL input to 0V (0V = OFF; 5V = ON).
8. Install the gate enabling D-sub 15 dongle onto the D-sub 15 connector on the RF Driver.
9. Connect the appropriate DC Power Supply to the RF Driver
  - a. L20S/L20G: 28V DC
  - b. L20SP/L20GP: 48V DC
  - c. L20SD/L20GD: 28V DC for Continuous Wave operation. 48V DC for Super Pulse operation

**NOTE** Red wire is positive. Black wire is negative.

**NOTE** The RF driver can be modulated at frequencies from 0 Hz to 100 kHz. Optimal laser performance can be expected at a frequency range of 1-15 kHz.

10. Verify the beam path is pointed at an appropriate beam blocking device.



### Eye Protection Required

This laser can cause mild to severe burns if skin or eyes are exposed to the beam or scattered radiation. Protective eyewear should be worn at all times.

11. Remove the protective tab from the aperture.
12. Open the laser shutter (if present).



Operate the shutter using the lever closest to your body. Never pass your hand in front of the laser beam to operate the shutter.

13. Plug in or apply the DC power supply to the RF Driver. The RF Driver is enabled after a 5 second delay, as indicated by the LED on the D-sub 15 dongle. The LED is red during the safety delay and turns amber when the RF Driver is enabled.



The red LED on the laser indicates the laser is powered. When the laser is powered, it is able to lase upon input of a control signal.

# Laser Operation Instructions

## *Operating the Laser*

14. To activate the laser beam, apply 5V through the TTL gate (0V = OFF; 5V = ON).

**NOTE:** For Super Pulse operation, using the 48V DC power supply, the laser is designed to be run up to:

- a. L20S: 25% duty cycle and pulse length up to 400 $\mu$ s.
- b. L20G: 30% duty cycle and pulse length up to 500 $\mu$ s.

### **CAUTION**

Running above the duty cycle or pulse length may damage the RF driver. The internal protection program will interrupt user signal beyond these parameters, making the output inconsistent.



# Laser Operation Instructions

## Water Cooling Diagram

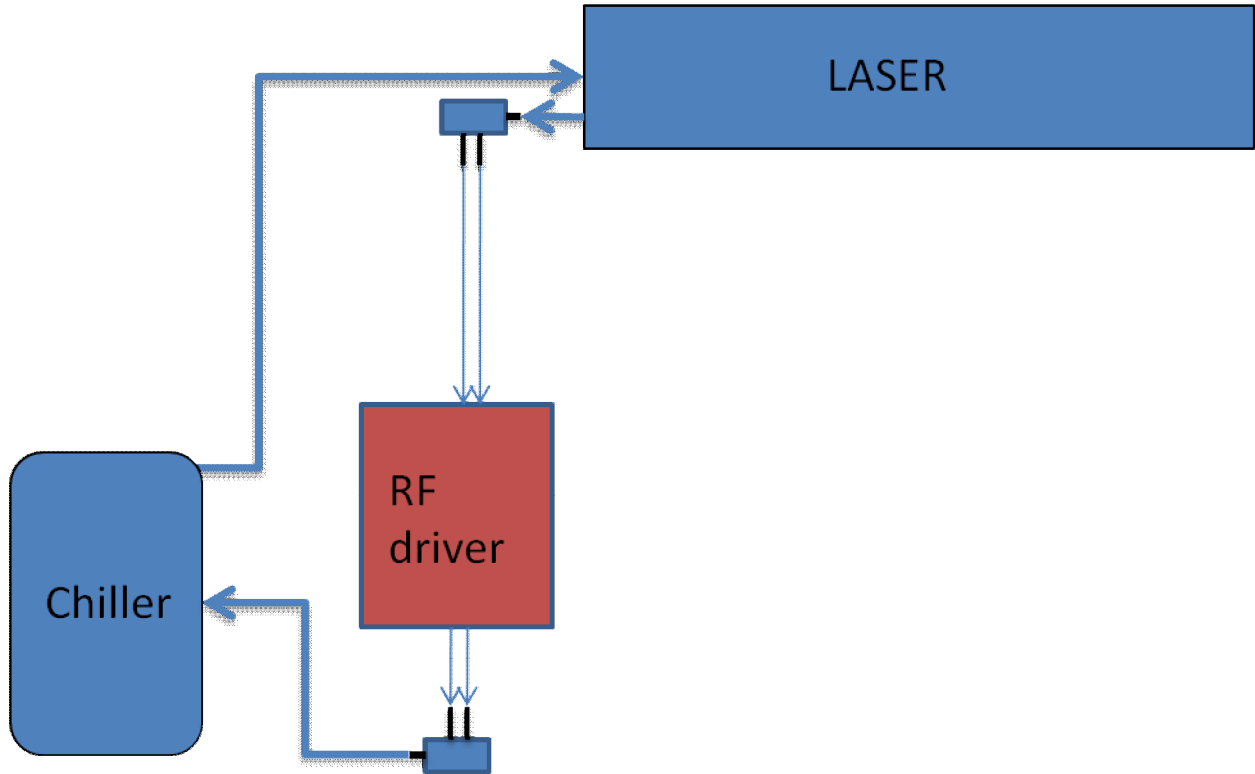

# Laser Operation Instructions

## *Water Cooling Connection Instructions*

If your laser is water-cooled, your laser comes with a kit containing the parts required to connect your laser to your chiller (chiller not provided).

For optimal performance with your water cooling system, keep the laser balanced, cool the laser equally, and keep the laser stable.

The quick connect tubing fittings are made by PISCO ([www.pisco.com](http://www.pisco.com)). These fittings are easy to use.

### **Assemble the PISCO fittings**

1. Cut the end of the tubing clean and flat.
2. Assure that the outer surface of the tubing is free of defects for the first ½+(13mm)
3. Assure that the tubing is round (not distorted).
4. Verify that the tubing is the correct diameter for the fitting.
5. Insert the tubing into the fitting and push it on as far as possible. It should go in approximately 0.7+(18mm)
6. Pull gently on the tubing to verify that the small Stainless Steel teeth in the fitting are grabbing the tubing securely.
7. The fitting is ready to be used.

### **To Remove**

1. Push the tubing gently into the fitting.
2. Push the ring into the fitting. This will release the small Stainless Steel teeth from the tubing.
3. While holding the ring close to the fitting, gently pull the tubing out of the fitting.
4. The fitting can be removed and replaced on the tubing many times, until the end of the tubing becomes scratched. If the end of the tubing is scratched, it should be cut back to expose smooth surface.

### **To Operate**

1. Always turn on/off the water chiller and the laser power at the same time.
2. If the coolant is running while the laser power is off, condensation can occur. This will damage the laser electronics.





# Laser Operation Instructions

## Wiring Diagram

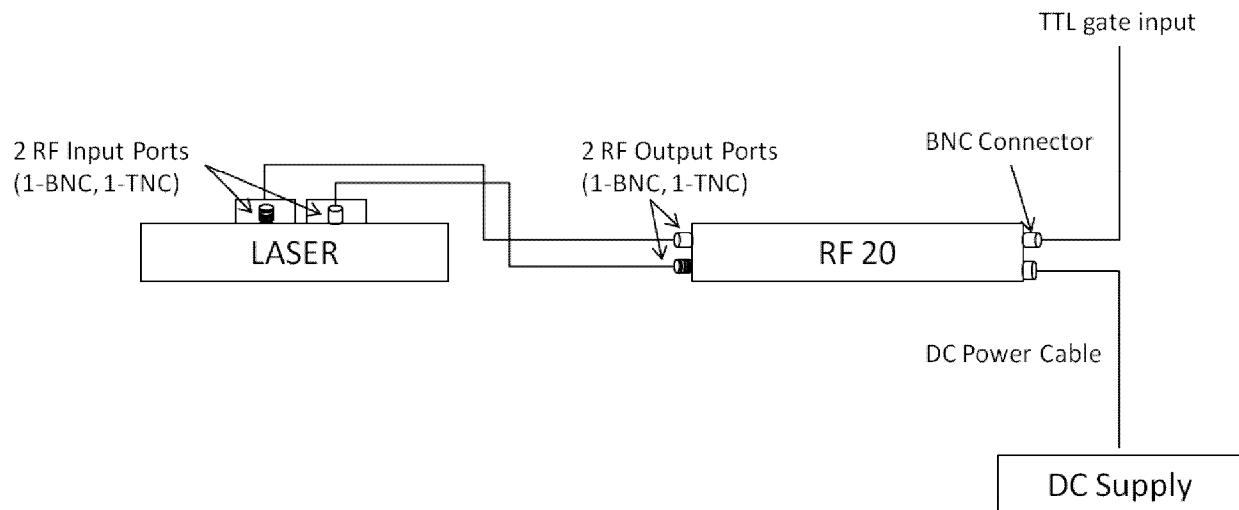

### Note

The correct DC Supply varies with the laser model.

L20S or L20G: Connect a 28V 240W DC power supply for CW operation

L20SP or L20GP: Connect a 48V 240W DC power supply for Super Pulse operation

L20SD or L20GD: Connect a 28 V 240W DC power supply for CW operation OR  
connect a 48V 240W DC power supply for Super Pulse operation



# Laser Operation Instructions

## Laser System Connection Diagrams

### FRONT VIEW

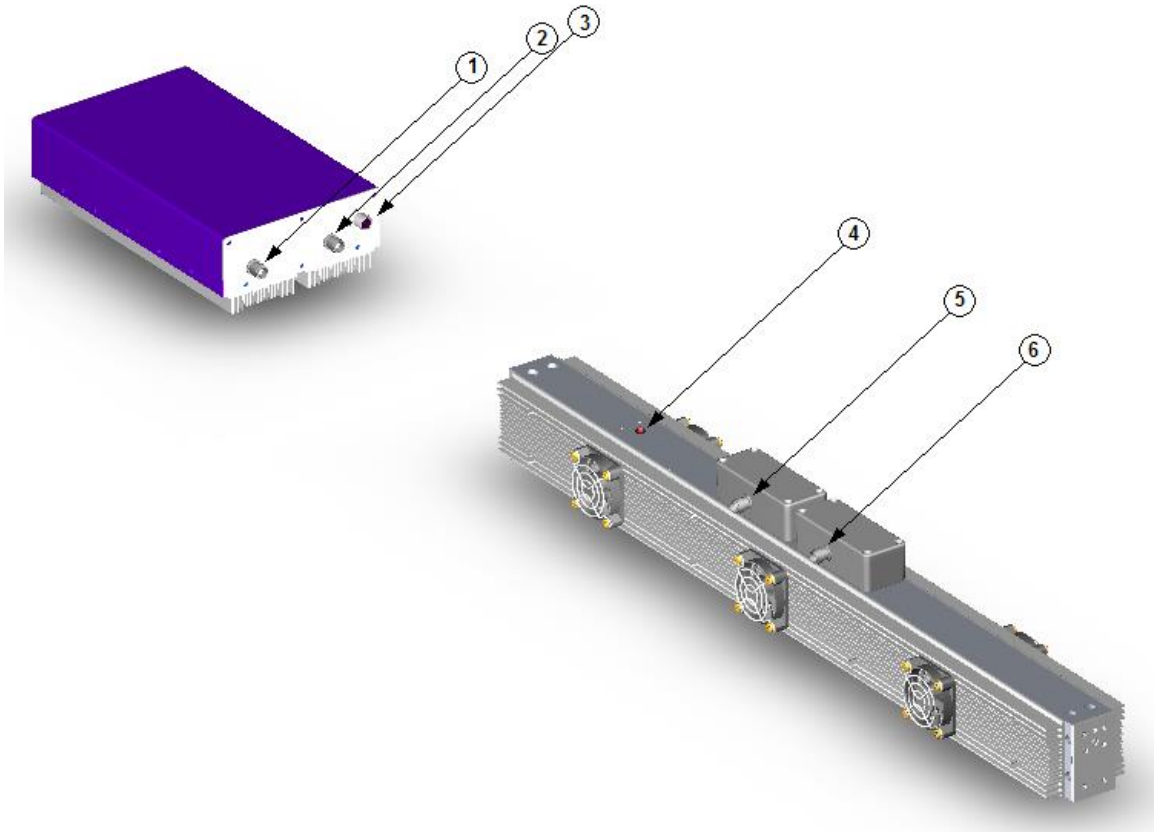

1. RF Output BNC
2. RF Output TNC
3. Not used
4. Laser Power Red LED
5. RF Input TNC
6. RF Input BNC

# Laser Operation Instructions

## Laser System Connection Diagrams

### REAR VIEW

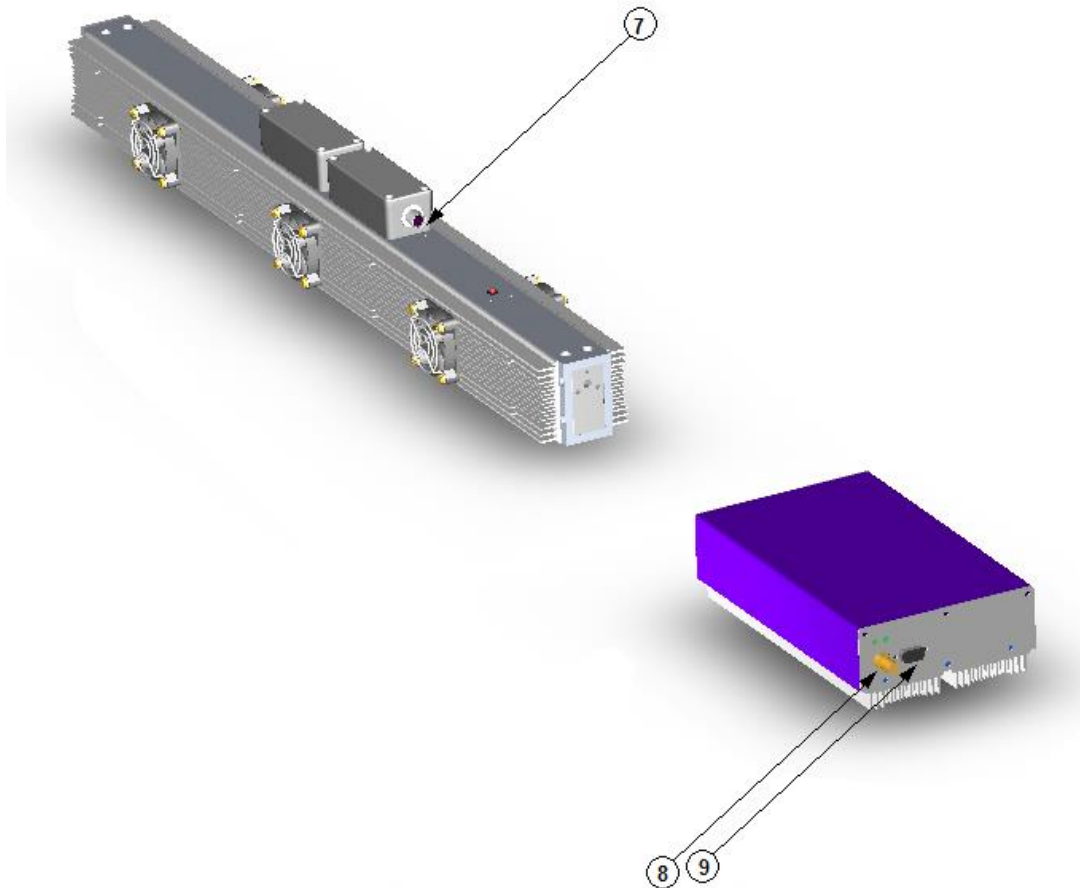

- 7. Not Used
- 8. BNC TTL Gate Input
- 9. Connector Input Compact D-sub 15

# Laser Specifications

## L20G Mounting Dimensions (Water Cooled)

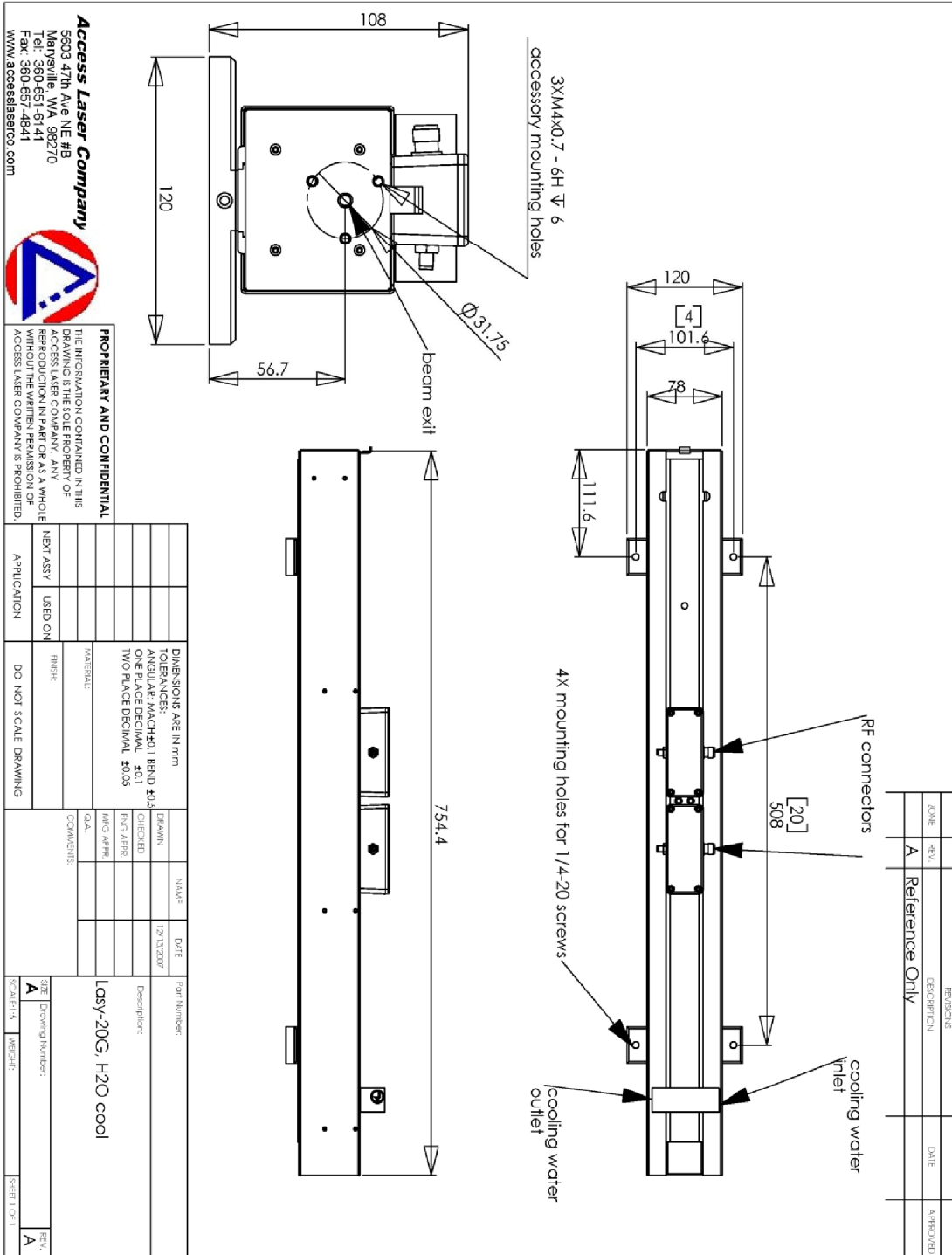

# Laser Specifications

## L20S, L20SP and L20SD Specifications

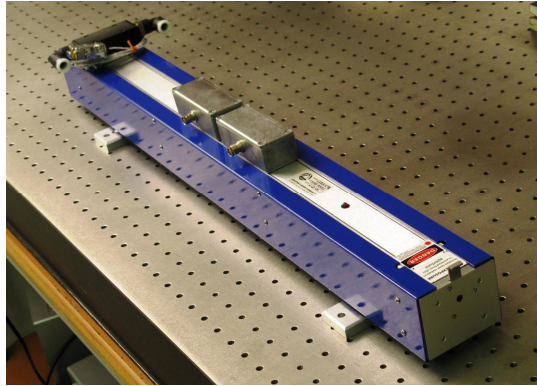

Model	L20S	L20SP	L20SD
Wavelength (μm)	10.55 - 10.63	10.55 - 10.63	L20D has features of both L20S and L20SP when the appropriate DC power supply is used.
CW Power (W)	20	12 (average)	
Peak Power (W)	20	50	
Power Stability	±2%	±2%	
Mode Quality (M <sup>2</sup> )	< 1.1	< 1.1	
Beam Waist Diameter	2.4 mm	2.4 mm	
Waist Location	Output Coupler	Output Coupler	
Full Div. Angle	5.5 mrad	5.5 mrad	
Polarization	Horizontal	Horizontal	
Rise Time (μs)	200	100	
Fall Time (μs)	200	100	
Supply Voltage (DC)	28V 500W	48V 500W	
Electronic PWM Parameters	Any frequency up to 100 kHz, duty cycle 0-100%	Any frequency up to 100 kHz, duty cycle 0-25%, pulse length to 0.4 ms	
Cooling Requirement <sup>1</sup>	Water Cooled	Water Cooled	1500W Chiller Stability ±0.1° C Flow Rate 0.5 GPM
Working Temperature	5-40° C	5-40°	
Dimensions (LxWxH, inch)	30x3x3.8	30x3x3.8	

### Options Available

- 5.5μm with CO gas fill (Model L20CO)
- Stabilization to ±1% with Line Tracker
- 11.2μm with 13CO<sub>2</sub> isotope gas fill

# Laser Specifications

## L20G, L20GP, and L20GD Specifications

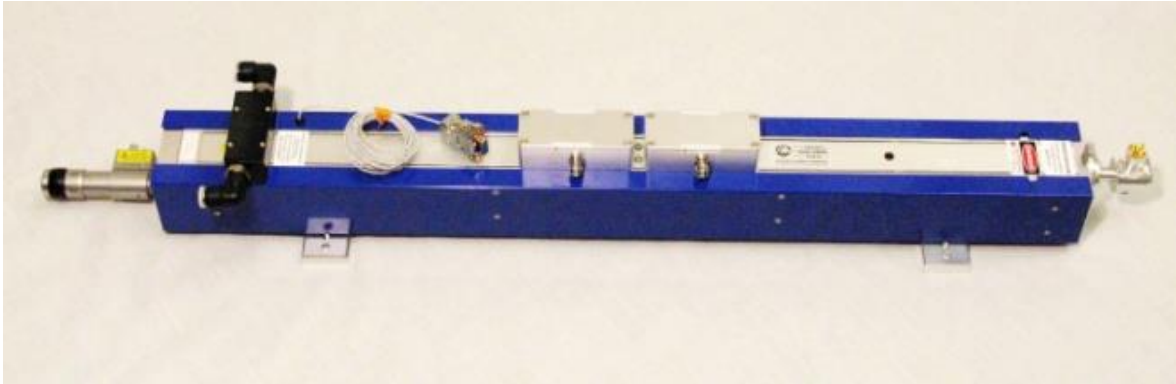

Model	L20G	L20GP	L20GD
Wavelength (μm)	9.2 - 10.7	9.2 - 10.7	L20GD operates with features of either L20G or L20GP, depending on which DC power supply is used.
No. of Lines	50	55	
CW Power (W)	8	5 (average)	
Peak Power (W)	8	24	
Power Stability	±5%	±5%	
Mode Quality (M <sup>2</sup> )	< 1.2	< 1.2	
Beam Waist Diameter	2.4 mm	2.4 mm	
Full Div. Angle	5.5 mrad	5.5 mrad	
Polarization	Vertical	Vertical	
Rise Time (μs)	200	100	
Fall Time (μs)	200	100	
Supply Voltage (DC)	28V 500W	48V 500W	
Electronic PWM Parameters	Any frequency up to 100 kHz, duty cycle 0-100%	Any frequency up to 100 kHz, duty cycle 0-30%, pulse length to 0.5 ms	
Cooling Requirement <sup>1</sup>	Water Cooled	Water Cooled	
Working Temperature	5-40° C	5-40° C	
Dimensions (LxWxH, inch)	32x2.8x3.8	32x2.8x3.8	

### Options Available

- 5.5μm with CO gas fill (Model L20GCO)
- Stabilization to ±1% with Line Tracker
- 11.2μm with <sup>13</sup>CO<sub>2</sub> isotope gas fill

# Laser Specifications

## RF Driver Specifications

Model	RF20	RF20-P	RF20-D
Features	Standard	Super Pulse	Smart Driver that can be either Standard or Super Pulse
	External TTL Control Input up to 100kHz		
	Built-in Plasma Ignition Signal at 2.5kHz		
Frequency	40.68 MHz		
Supply Voltage	28V DC	48V DC	28V or 48V DC
Supply Current	14 Amps	8 Amps	14 or 8 Amps
Output Power	2x120W up to CW	2x300W up to 25% or 450µs	2x120W up to CW, 2x300W up to 25% or 450µs
Dimensions (inches)	9.6 x 3.4 x 5.63		

### CAUTION

Never connect the DC supply to the RF Driver with the wrong polarity, or the RF driver will be damaged.

### CAUTION

Never operate the RF Driver without its output properly connected to the laser.

### CAUTION

Do not block the air flow to and from the heat sink, or the RF Driver will be damaged.

### CAUTION

On air cooled versions, if the fans fail, the RF driver will stop immediately.



## Appendix A: RF Driver D-sub 15 Connector

RF Driver D-Sub 15 Connection Port  
Pin Number Diagram

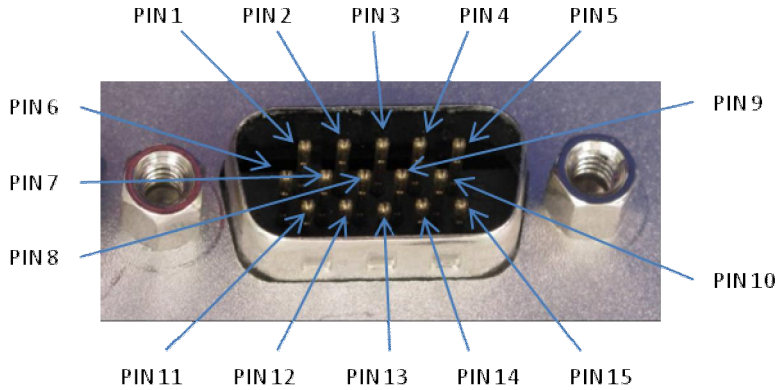

Custom Controls and Signals at the D-sub 15 Connector

Pin #	FUNCTION	MODE 0 Action / Result	MODE 1 Action / Result
1	5 VDC, 20 mA capacity, power ready. Connection to an external red LED.	Red LED off / No power.	<b>Red LED on / Powered</b>
2	Connected to an external green LED to indicate laser ready status, up to 10 mA supplied.	Green LED off / Laser not ready. Fault due to RF overtemp, interlock opened, or key switch fault.	<b>Green LED on / Laser is ready to fire</b>
3	Safety Key Switch Connection. When this pin is enabled by PIN 6 and there is a power outage or opening interlock (PIN 4), this pin needs to be pulled high and then low again to restore laser operation.	Short to PIN 15 / DC power supply is connected to laser	Open / No DC power to laser
4	Safety Interlock = top level laser enable. This pin also needs to be enabled by PIN 6.	<b>Short to PIN 15 / Laser enabled at the top level</b>	Open / Laser not operational
5	AVC (Pin 11) Enable	Short to PIN 15 / Enables AVC together with PIN 10	<b>Open / Disables AVC</b>
6	CDRH Safety Mode. Controls key switch on PIN 3 and Safety Interlock of PIN 4.	Short to PIN 15 / Enables key switch	<b>Open / Disables key switch</b>
7	Gate for Laser Enable	Not connected or connected to 0V / Laser disabled	<b>Connected to 5V or to PIN 1 / Laser enabled</b>



## Appendix A: RF Driver D-sub 15 Connector

Pin #	FUNCTION	MODE 0 Action / Result	MODE 1 Action / Result
8	Time delay control: 5 seconds between initial power on and lasing	Short to PIN 15 / No delay	<b>Open / Delay True</b>
9	Discharge conditioning	Open / Conditioning on (Recommended for surgical applications)	<b>Open / Conditioning on (Recommended for marking applications)</b>
10	Gate 2, connected to BNC input, signal is provided by the customer to turn the laser on/off electronically.	<b>Not connected or connected to 0V / Laser off</b>	Connected to 5V / Laser on
11	Input, AVC <sup>1</sup>	This is an analog function therefore there are more than two modes. <sup>2</sup>	
12-14	Do not use		
15	Ground	N/A	N/A



# Appendix A: RF Driver D-sub 15 Connector

## ENGINEER'S NOTES

### Schematic

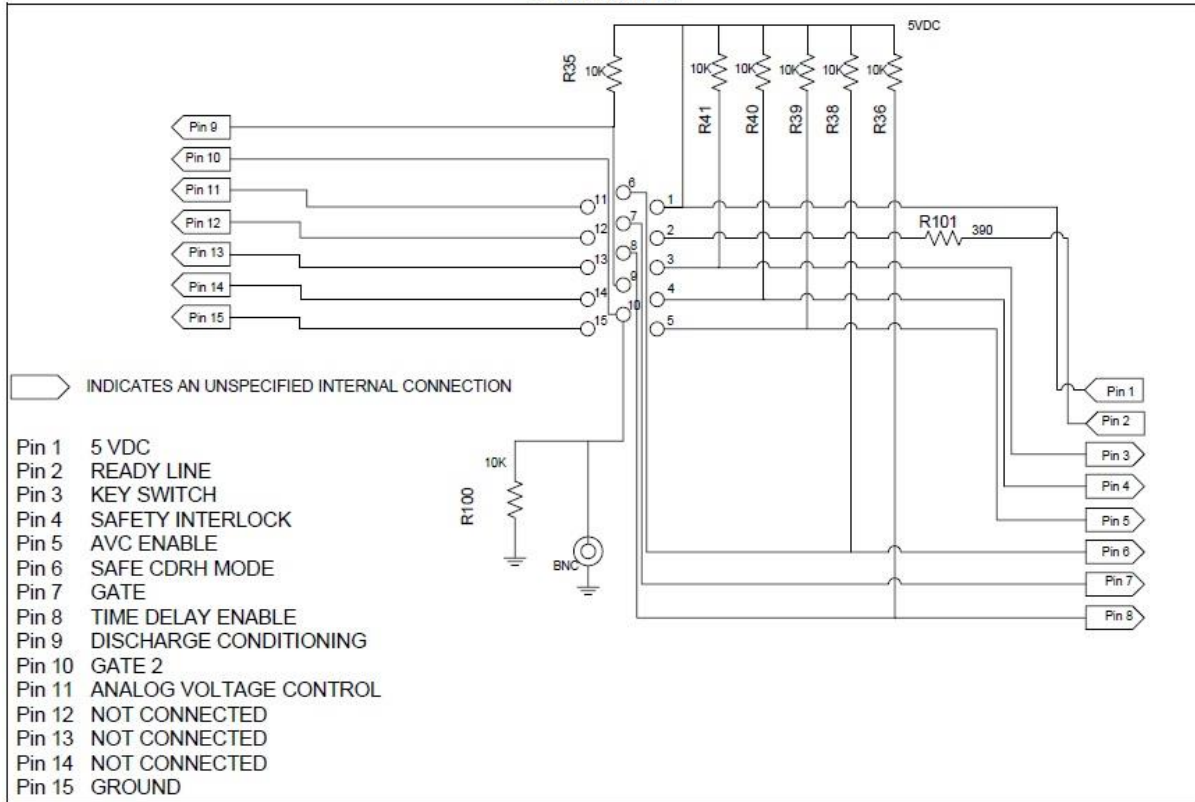

## Appendix A: RF Driver D-sub 15 Connector

### ENGINEER'S NOTES (cont.)

- PIN 1 5V DC regulated supply output line. 20 mA source capacity. Intended to light remote Power On+LED. (**Important:** no internal series current limiting resistor provided on this line.)
- PIN 2 This output line is a Laser Ready+indicator in both the Safe CDRH mode and the OEM mode. When LOW, it indicates a fault has occurred and the laser is shut down: RF amplifier over heated, DIN cable not connected or RF cable not connected or damaged. The Amplifier will operate for approximately one minute on start-up before the processor checks for faults. This allows some troubleshooting before a Fault Shutdown. In the Safe CDRH mode two additional faults are indicated by PIN 2. The Key Switch fault status (see description of PIN 3) and the Interlock Fault Status (see description of PIN 4). This is an un-buffered output of 3.8V DC with internal 390 ohm current limiting resistor R101. If remoting this signal, we recommend buffering.
- PIN 3 Key Switch is an active LOW input line. The Key Switch is a safety requirement for many laser systems. PIN 3 is internally pulled HIGH with a 10k resistor R41. The Key Switch is only functional in the Safe CDRH mode (PIN 6 LOW). To implement a Key Switch use the normally open contacts. (Key Switch on+ is PIN 3 pulled LOW). The Key Switch has to be turned on before the laser can operate. When there is a power outage the Key Switch has to be recycled to restore laser operation. The key should not be removable when the Key Switch is turned on.
- PIN 4 Safety Interlock is an active HIGH input line. The Safety Interlock is a safety requirement for some laser systems. When PIN 4 is functional any logic HIGH transition on PIN 4 halts lasing. PIN 4 is internally pulled HIGH with a 10k resistor R40. The Safety Interlock is only functional in the Safe CDRH mode (PIN 6 LOW).
- PIN 5 Analog Voltage Control (AVC) input enable line. The AVC input is a LOW enable. PIN 11 becomes active as a 0V DC to 5V DC analog PWM control line. See definition of PIN 11 for AVC mode of operation. When PIN 5 is pulled HIGH (internal 10k pull up resistor R39), lasing is controlled exclusively by the logical result of Gate (PIN 7) AND Gate-2 (PIN 10).
- PIN 6 Safe CDRH mode LOW enable input line. The Key Switch (PIN 3) and the Safety Interlock (PIN 4) becomes active. When PIN 6 is pulled HIGH (internal 10k pull up resistor R38) these two safety devices are disabled. Operation with PIN 6 disable (HIGH) is generally referred to as the OEM mode+.



## Appendix A: RF Driver D-sub 15 Connector

- PIN 7 Gate is an active HIGH lasing enable input. Gate is pulled LOW internally (processor controlled 10k pull down resistor). To initiate lasing, both the Gate (PIN 7) and Gate-2 (PIN 10) input lines must be pulled HIGH externally by user.
- PIN 8 Delay Enable is an active HIGH input. When active, while operating in the OEM mode (PIN 6 HIGH), a 5 second delay is enforced every time the DC supply electrical power is cycled. PIN 8 must be enabled to operate in the Safe CDRH mode. When active, while operating in the safe CDRH mode, a 5 second lasing safety delay is enforced every time the Key Switch is cycled. The Delay Enable line is internally pulled HIGH by a 10k resistor R36. User must pull PIN 8 LOW to suppress the safety delay (not recommended).
- PIN 9 Discharge Conditioning active HIGH enable input line. PIN 9 is internally pulled HIGH by a 10k resistor R35. User must pull PIN 9 LOW to suppress Discharge Conditioning.
- PIN 10 Gate-2 is an active HIGH lasing enable input. Gate-2 is pulled LOW by an internal 10k pull down resistor R100. To initiate lasing, both the Gate-2 (PIN 10) and Gate (PIN 7) input lines must be pulled HIGH externally by the user. Additionally, Gate-2 is wired directly to the external BNC connector.
- PIN 11 AVC (Analog Voltage Control) input. See definition of PIN 5. A 0V DC to 5V DC analog voltage on PIN 11 results in a proportional 0% to 100% Pulse Width Modulated (PWM) laser output. The PWM frequency is 2.5 kHz. To enable the internal PWM drive signal in the AVC mode: PIN 5 must be held LOW by user, Gate-2 (PIN 10) must be pulled HIGH by user, Gate (PIN 7) can be left open (NC) or pulled HIGH by user and a non-zero voltage between 0V DC and 5V DC must be present on PIN 11 for lasing to occur. By the way of Example 1, 1V at this pin will cause the PWM to operate at a 20% duty cycle, 3V at 60%, etc. (Note: Gate (PIN 7) is pulled HIGH internally by the processor. PIN 7 is functional as a lasing sizable when pulled LOW by the user.)
- PIN 12 Disabled
- PIN 13 Disabled
- PIN 14 Disabled
- PIN 15 Ground



## Appendix B: Optional Accessories

### *Differential Micrometer (L20G Only)*

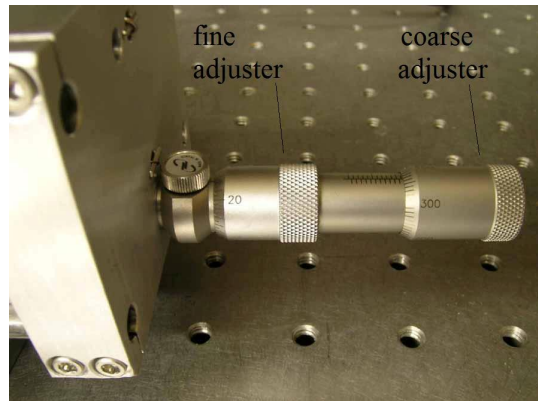

A differential micrometer is used to adjust the wavelength, as well as maximize the output power and mode quality. Two knobs are available for tuning, a coarse adjuster (micrometer) and a fine adjuster (differential knob).

The micrometer is used to tune to the wavelengths listed in the provided reference table. We also recommend using a mode screen to verify the tuning. The micrometer has an adjustment range of 0-13mm with markings at each 0.5mm. The micrometer knob is scaled at 0.01mm per division.

The differential knob has an adjustment of 0-0.2mm with markings at each 0.025mm. The differential knob is scaled at 0.0005mm per division.

### **CAUTION**

The differential knob should not be driven outside of its marked range or damage may occur. The micrometer should not be driven outside the range marked in the reference table.

## Appendix B: Optional Accessories

### LC3 Laser Controller Diagram

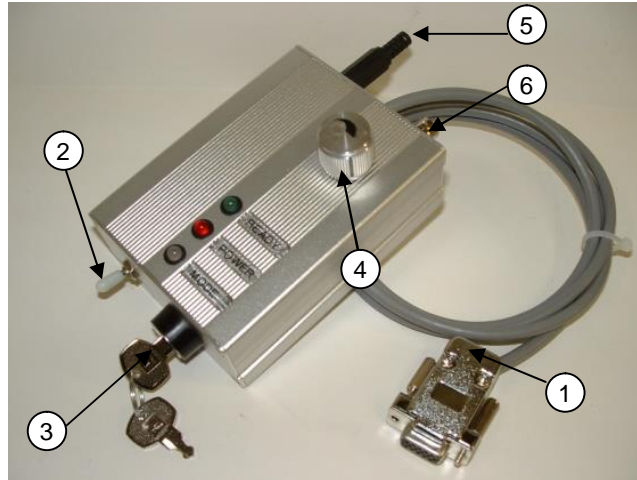

There are six components to the LC-3, pictured above.

1. D-Sub 15 Connector. This needs to be plugged into the RF driver.
2. The Mode Switch. The Mode Switch has three positions.
  - a. When in the **Up** position, the LC-3 operates in PULSE mode. This provides a partial power range, from 0-25%. The partial range function is for super-pulse operations where the laser is restricted to operate at lower duty cycles. It can also be used as a fine adjustment of power at low duty cycles for models without super pulse.
  - b. In the middle position, the LC-3 is in Standby.
  - c. In the **Down** position, the LC-3 operates in CW mode. This provides the full power range (0-100%).
3. Key Switch. The Key Switch needs to be turned ON for the laser to operate. In addition, if there is a power outage or interruption of the Interlock circuit, it is necessary to recycle the Key Switch (turning OFF and back ON again) before operation can resume. As a safety precaution, the key cannot be removed in the ON position.
4. Power adjustment knob through Pulse Width Modulation (PWM). The PWM frequency is typically 2.5 kHz. This knob adjusts the average power through duty cycle in the range determined by the position of the Mode Switch. Turning the power adjustment knob clockwise turns the power up.

## Appendix B: Optional Accessories

### *LC3 Laser Controller Diagram*

5. Interlock Plug. The interlock connector on the controller is a 1/8+ stereo plug which is internally self-shorting. If nothing is plugged into the stereo port, the LC-3 defaults to ON and the laser is ready to go. If an Interlock plug is used, two of the Interlock conductors need to be shorted together for the laser to operate. If their connection is broken, the laser will shut off.

If any of the interlocks are triggered or the DC power is interrupted, the conductors need to be reconnected AND the Key Switch will need to be cycled OFF and back ON to turn the laser back on.

6. BNC Connector. A BNC connector can accept a TTL source, such as a pulse generator, to gate the laser on and off. 0V is OFF and 5V is ON. The gate can be electronically modulated up to 100 kHz.



## Appendix B: Optional Accessories

### *Laser Operation Instructions for LC3*

**NOTE:** *If using your own controller, follow the instructions under “Laser Operating Instructions”.*

1. Close the laser shutter (if present).
2. Direct the laser toward an appropriate target, such as a power meter or a beam-blocking device. (See Safety Information regarding appropriate beam blocking devices.)
3. Secure the laser to a bench top.

#### **⚠ CAUTION**

Do not torque, twist or bend the laser body during the mounting process. Applying uneven pressure to the laser body may distort the laser body, causing poor performance and possible damage.

4. Connect the Cooling System
  - a. Air Cooled Lasers (where cooling is provided by the end user)
    - i. If no cooling is built in to your laser, you are responsible for providing sufficient cooling to maintain the laser specifications. (See Air Cooling Section for specifications.)
    - ii. Connect your air cooling system to the laser.
  - b. Built-in Fan Cooled Lasers

Connect the 12V DC supply to the fan power connector.
  - c. Built-in Water Cooled Lasers
    - i. Connect the tubing to the PISCO fitting as described in the Water Cooling Connection Instructions.
    - ii. Connect the tubing to the laser and the chiller, as shown in the Water Cooling Connection Diagrams. Be sure that the tubing input and output are the same on both sides of the laser.
5. Install the LC3 Controller onto the D-sub 15 connector on the RF driver.
  - a. Assure that the Key Switch is in the OFF position.
  - b. Place the Mode Switch in STANDBY (middle) position.
  - c. The laser is now in standby mode.





## Appendix B: Optional Accessories

### *Laser Operation Instructions for LC3*

6. Connect the RF Driver to the laser with the two coax cables, using the TNC and BNC connectors, as shown in the Connection Diagrams.
7. Connect the appropriate DC Power Supply to the RF Driver
  - a. L20: 28V DC
  - b. L20P: 48V DC
  - c. L20D: 28V DC for Continuous Wave operation. 48V DC for Super Pulse operation

**NOTE** Red wire is positive. Black wire is negative.

**NOTE** The RF driver can be modulated at frequencies from 0 Hz to 100 kHz. Optimal laser performance can be expected at a frequency range of 1-15 kHz.

8. Verify the beam path is pointed at an appropriate beam blocking device.



#### Eye Protection Required

This laser can cause mild to severe burns if skin or eyes are exposed to the beam or scattered radiation. Protective eyewear should be worn at all times.

9. Remove the protective tab from the aperture.
10. Open the laser shutter (if present).



Operate the shutter using the lever closest to your body. Never pass your hand in front of the laser beam to operate the shutter.

11. Plug in or apply the DC power supply to the RF Driver. The red **POWER+LED** should light.



The red LED on the laser indicates the laser is powered. When the laser is powered, it is able to lase upon input of a control signal.

12. Turn the Key Switch to the ON position. After a 5 second delay, the **READY+** LED should turn green. This indicates that the laser is ready to deliver power upon command.



## Appendix B: Optional Accessories

### *Laser Operation Instructions for LC3*

13. For Continuous Wave (CW) operation, turn the Mode Switch to CW (0-100%) (down position). The Mode LED should turn red as the laser delivers power.
14. Turn the power adjustment knob to adjust the duty cycle from zero to 100 CW (Continuous Wave) (0-100%). The duty cycle is increased as the knob is turned clockwise.
15. For Super Pulse operation, turn the Mode Switch to PULSE (0-25%) (up position). The Mode LED should turn blue as the laser delivers power. The knob will adjust the duty cycle from zero to 25%, increasing power as it is turned clockwise.

**NOTE:** For Super Pulse operation, using the 48V DC power supply, the laser is designed to be run up to 30% duty cycle and pulse length up to 400 $\mu$ s.

#### **CAUTION**

Running above 30% duty cycle or 400 $\mu$ s pulse length may damage the RF driver. The internal protection program will interrupt user signal beyond these parameters, making the output inconsistent.



# Appendix B: Optional Accessories

## Line Tracker (Optional)

### CLOSED-loop Spectrum/Power Stabilizer

A line tracker is available as an accessory for any . S or . G model laser. A line tracker maintains a fixed wavelength at a high degree of power and frequency stability in a CO<sub>2</sub> laser. The line tracker consists of a beam sampling assembly, a Piezo actuator and a controller. The Line Tracker can be connected to a computer through an RS-232 interface for information and data logging. Any of the Access Laser . S (stabilized) or . G (grating tuned) lasers can be equipped with Line Tracker to achieve more robust, longer term operation of  $\pm 1\%$  power stability, even in outdoor applications where the ambient environment fluctuates.

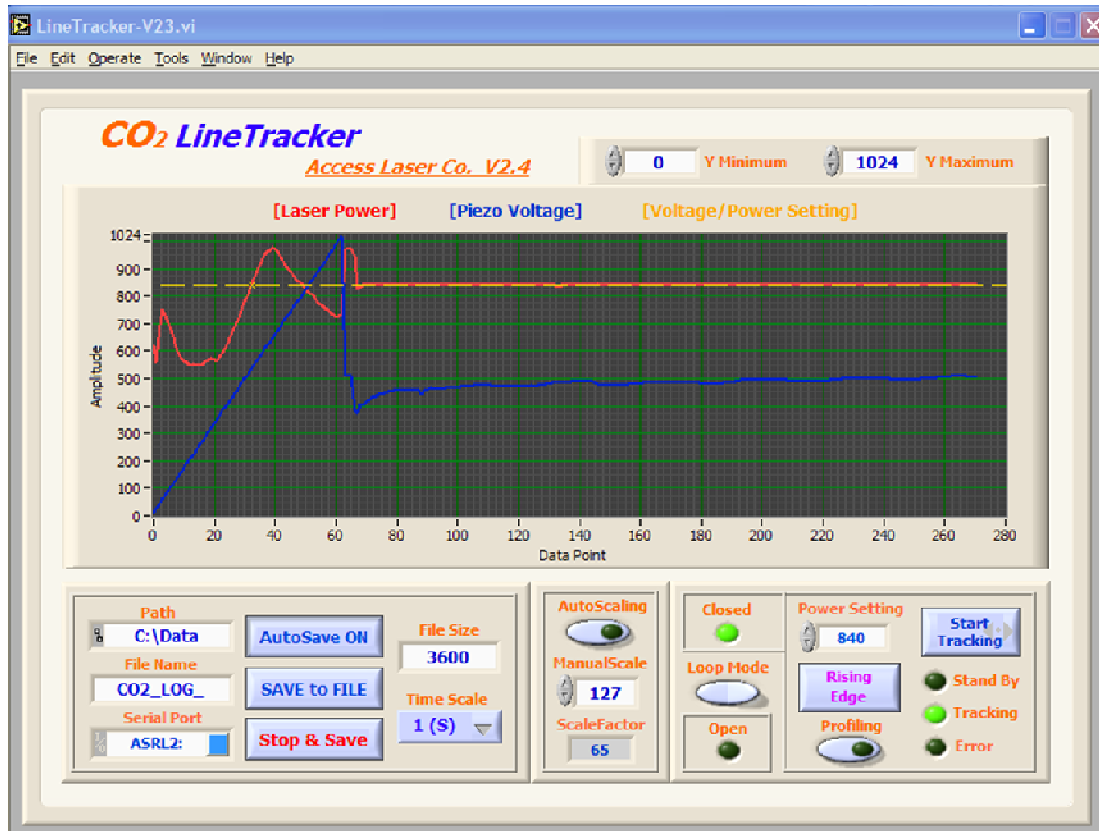

Screen shot of the Line Tracker computer interface. This plot was obtained with a Merit laser.

## Appendix C: Warranty Repairs

If a failure should occur, please contact your Access Laser Company representative, or contact our Headquarters at 1-425-582-8674 or at [service@accesslaser.com](mailto:service@accesslaser.com). A Company representative will determine whether your laser should be returned for repair or maintenance. If the laser needs to be returned, a Return Merchandise Authorization (RMA) will be issued. Any laser returned without an RMA will be at your sole expense.

An ALC representative will make a determination regarding shipping costs. Typically, for failures within the first 45 days, ALC pays all shipping costs to and from ALC. For failures after 45 days, but within the first year, the client shall be responsible for shipping costs to ALC. ALC will pay all shipping costs to return the item(s) to the client. Special considerations may apply. Be sure to verify shipping costs with your ALC representative.

When requesting an RMA please have the following information ready:

- Date of purchase
- Laser model
- Serial number the laser
- Serial number for the RF driver
- Date the issue was first discovered
- Brief description of the issue

Fill out the RMA as completely as possible. Include a copy of the RMA in the laser package. Also fax a copy to us at 1-425-582-8679, Attention: Service. When faxing the RMA please include the tracking number for the return shipment.

For any returns, please ship the item(s) to:

Access Laser Company  
Attn: Service Department  
917 134<sup>th</sup> St SW, Suite A1  
Everett, WA 98204

Include the laser and ALL accessories when returning the laser. This allows ALC to test each component and determine the source of the issue.

